

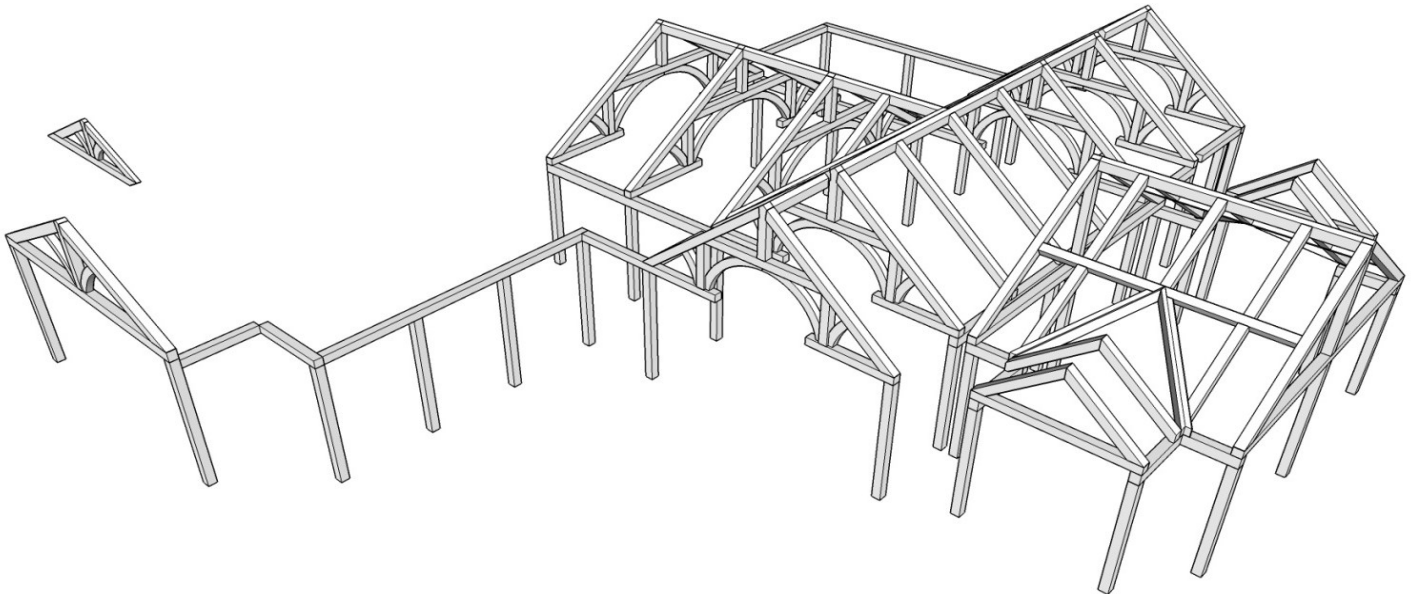

1948 Sharpe's Lane, Brockville, ON K6V 5T1  
 Office: (613) 498-2406 / Cell: (613) 803-3241  
[www.gibson timber frames.com](http://www.gibson timber frames.com)  
[info@gibson timber frames.com](mailto:info@gibson timber frames.com)

**Project:** Great Room, Master Suite, Kitchen & Porches  
**Location:** Calabogie, ON  
**Original estimate date:** March 2020

	<u><i>Eastern White Pine</i></u>	<u><i>Western Douglas Fir</i></u>	
<i>Shop Work &amp; Design:</i>	\$104,120.00	\$133,125.00	
<i>Delivery &amp; Installation:</i>	\$44,925.00	\$44,925.00	
<b>Total:</b>	<b>\$149,045.00</b>	<b>\$178,050.00</b>	+hst



Details:

Sanding of timbers:	Yes
Clear oil based stain:	Yes
Engineering of timber work:	Yes
Timber frame footprint (sq.ft.)	2,155.0

\* Please contact us for current pricing.