

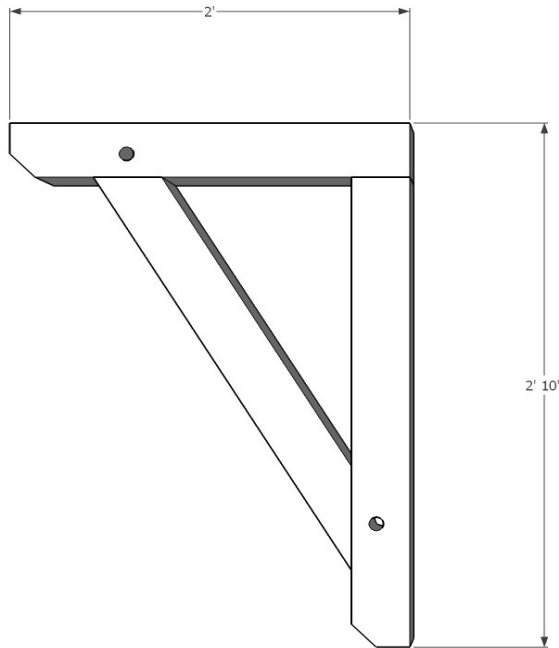

1948 Sharpe's Lane, Brockville, ON K6V 5T1
 Office: (613) 498-2406 / Cell: (613) 803-3241
www.gibson timber frames.com
info@gibson timber frames.com

Project: Brackets (Qty=5)
Location: Georgian Bay, ON
Original estimate date: March 2020

	<u><i>E. White Pine</i></u>	<u><i>Douglas Fir FoHC</i></u>	
<u>Shop Work & Design:</u>	\$2,505.00	\$2,635.00	
<u>Delivery & Installation:</u>	\$2,660.00	\$2,660.00	
Total:	\$5,165.00	\$5,295.00	+hst



Bracket x5

Details:

Sanding of timbers:	Yes
Clear oil based stain:	Yes
Engineering of timber work:	No

* Please contact us for current pricing.